

Fuel Water Separators - FWS : EngineTech

Most existing fuel filters are not designed to remove water. They are designed to remove solid contaminants.

EngineTech takes care of this shortcoming by removing virtually 100% of water from diesel fuel.

EngineTech eliminates water from diesel fuel before reaching the fuel pump and injectors. This prevents the major cause of fuel injection system failures.

Clean fuel means a smoother running engine and more cost effective operation.

EngineTech is a proven product. Prove it to yourself with an EngineTech Fuel / Water Separator.

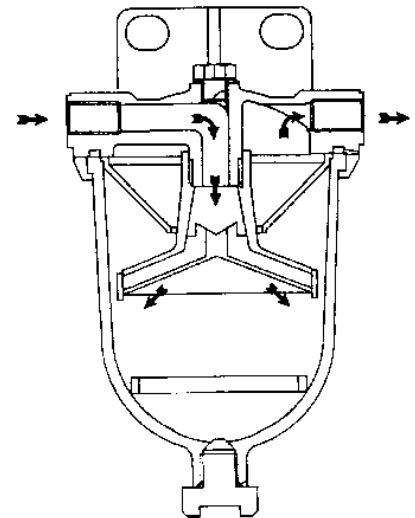

- Less Pump & Injector Wear**
- Less Downtime & Maintenance**
- Lower Fuel Consumption**
- Lower Exhaust Emissions**



www.dieselproducts.com

Tel.: 905-362-0423

Fax: 905-362-5015

Fuel Water Separators

Model 80

Max. flow

0.8 USG/ min 48 USG/ hr

0.65 Imp g/ min 40 Imp g/ hr

3.0LPM 180 ltr/ hr

Ports 9/16" - 18 UNF, straight thread
"O" ring seal

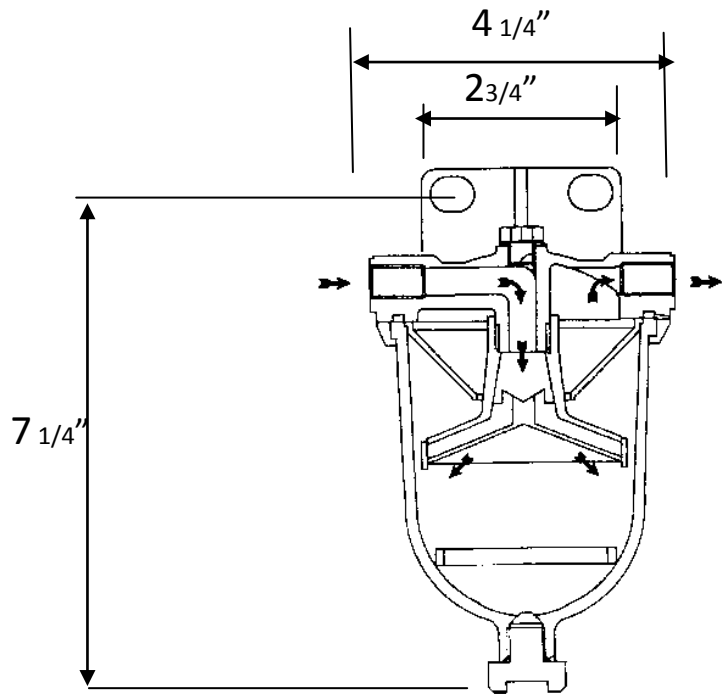

Model 200

Max. flow

1.6 USG/ min 95 USG/ hr

1.3 Imp g/ min 80 Imp g/ hr

6.0LPM 360 ltr/ hr

Ports 7/8" x 14 UN straight thread

